

Transportation & Mobility

# ELECTRIC DRIVE: HOW CAN YOU LEVEL UP?

Winning the race of rapid EVolution

## **ELECTRIC DRIVE: HOW CAN YOU LEVEL UP?**

Electric cars may well be the future of the automotive industry. Car manufacturers need to maximize the power of electric motors while reducing their mass and electromagnetic losses. In the race for e-drive, simulation is helping OEMs reach the best design and optimal combination of parameters.



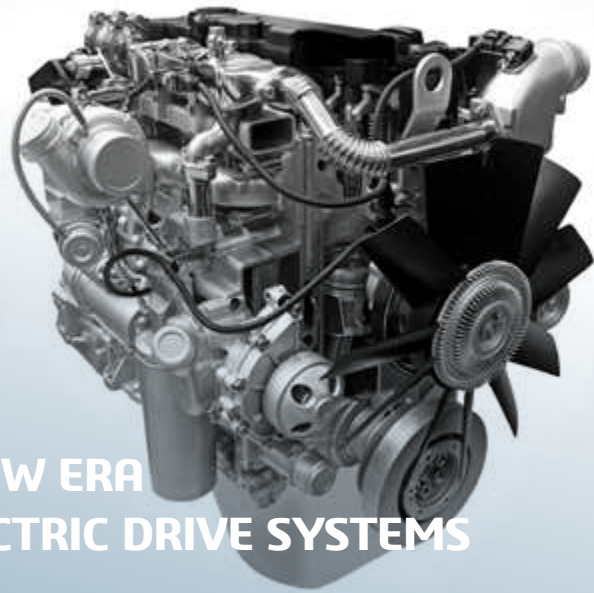

## THE NEW ERA OF ELECTRIC DRIVE SYSTEMS

### THE USUAL SUSPECTS

The care for the environment is not just a hot topic. It has reached a phase where public authorities are deploying regulations to limit the carbon footprint of vehicles. Car manufacturers are now facing unprecedented challenges. In Europe, where vehicles generate around 12% of total carbon dioxide, emission targets on new cars will decrease from 130 to 95 grams of CO<sub>2</sub> per km in 2021. OEMs will have to pay high fines if they don't reach that goal. Knowing that, they invest in electric vehicles (EVs) and plug-in hybrid electric vehicles (PHEVs) as a way to compensate for cars with high CO<sub>2</sub> emissions – typically SUVs that meet rising demand and generate high profit margins.<sup>1</sup>

**CO<sub>2</sub> emission targets on new cars will decrease from 130 to 95 grams of CO<sub>2</sub> per km**

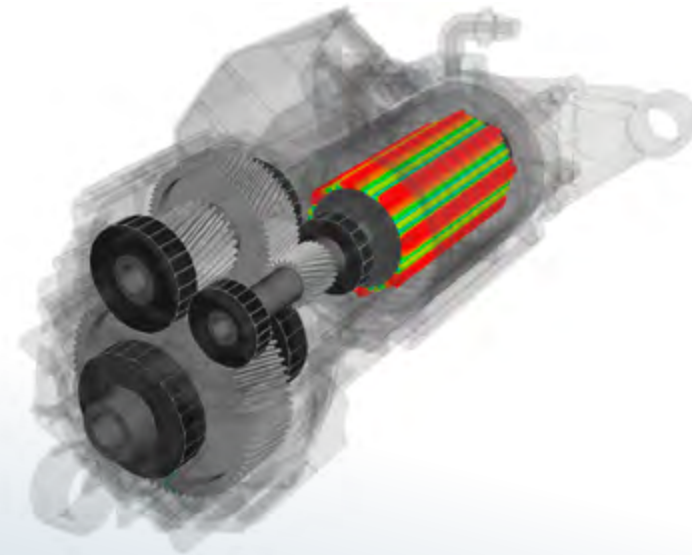

### TIME TO EVOLVE

Electric vehicles are nothing new. They have been in the picture since the dawn of the automobile. But they never became industrially relevant because gasoline was a cheaper energy source than electricity. Now green motives are turning the wheel. Auto makers have to reinvent electric powertrain and make it suitable for modern cars.

Expectations are high: customers demand the same level of price, performance and comfort in EVs and traditional vehicles. The OEMs' challenge consists in maximizing the electric motor power and torque while reducing the motor mass and electromagnetic losses. In a fast-changing industry landscape, they need to make their electric drive\* quieter, more powerful, flexible and reliable than their competitors.

**The challenge: maximizing power and torque while reducing the motor mass and electromagnetic losses**

\* The electric drive module typically consists of electric machine(s) and gearbox in a housing, often with a power electronics unit on or near the module.

## NEED FOR SPEED

Car makers have to cope with drivers' attitudes which are changing much faster than the usual automotive production cycle. The quickest route to development is also the quickest route to profit. There is a sense of urgency, as most businesses are investing more money than they are making in this field.

Businesses must embrace digitalization as rapidly as possible to speed up the cycles of electric drive improvement – compressing industry maturity into 10 years whereas it took 100 years to develop internal combustion engines.

**Only 6 years until EV adoption reaches critical mass and approximately 130 EV models will be introduced by 2022.**

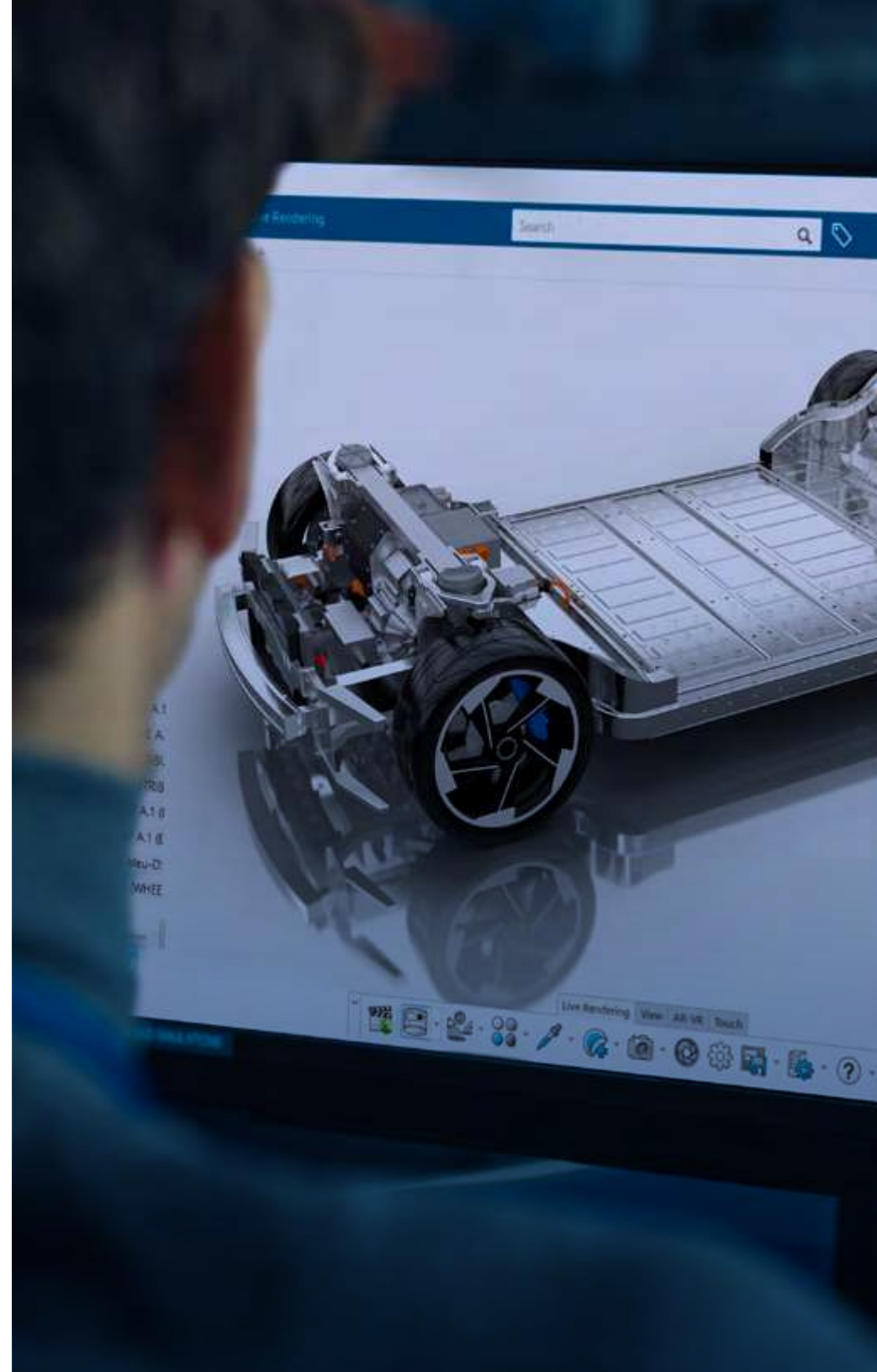

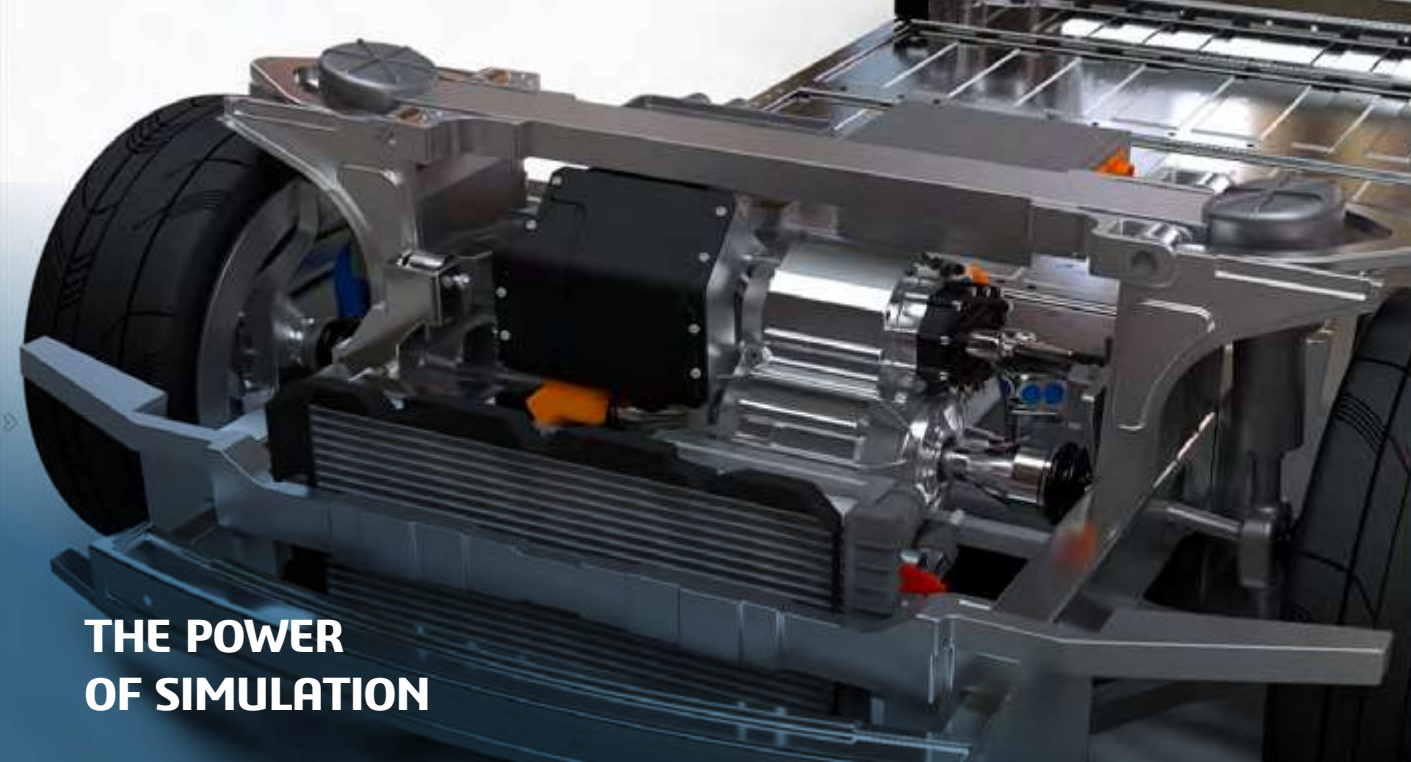

## THE POWER OF SIMULATION

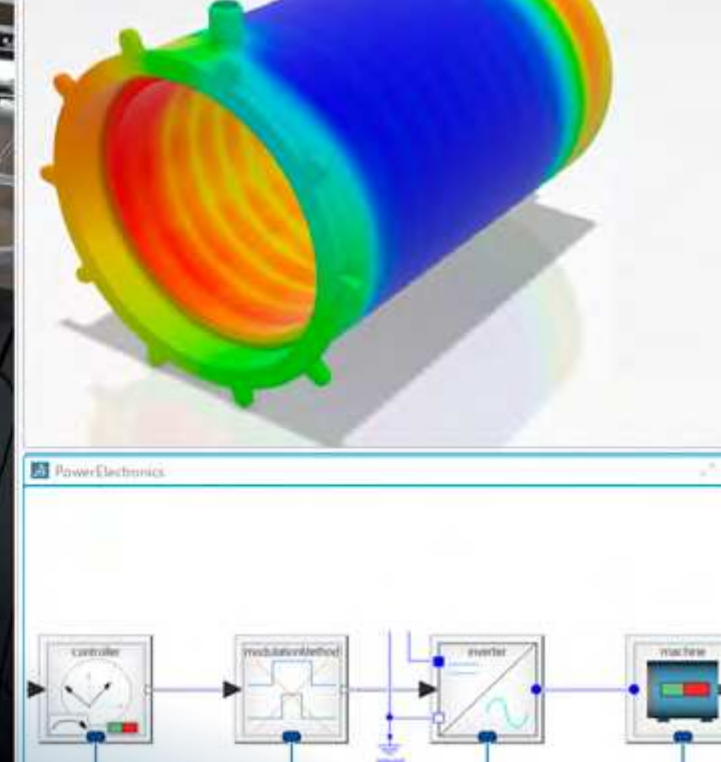

## NONLINEAR MODELING

Digital transformation allows companies to switch from drawing boards to virtual prototyping and validation. Simulation plays a starring role in this respect. It has greatly contributed to the progress of internal combustion engines. Indeed, it has been used to continuously optimize engine components like crankshaft, head & block assembly or exhaust manifolds. It has therefore helped downsize engines and make them more efficient and durable. **“The processes happening in the engine require highly nonlinear modelling to handle plasticity, contact, thermal effects, noise and vibration. That is not a trivial task”**, underlines Thomas Reimer, industry solutions manager at Dassault Systèmes.

Today, software is everywhere, from designing to testing and running. With more stringent regulation on CO<sub>2</sub> emissions, systems have grown into increasing complexity. A case in point, diesel engines rely on software to optimize fuel consumption by providing direct injection at high pressure and removing particles by combustion. **“These mechatronic systems that combine mechanical, electronics and software need high fidelity models to simulate upfront the system behavior in different situations”**, explains Gauthier Fanmuy, systems engineering portfolio director at Dassault Systèmes.

**Software is now everywhere, from designing to testing and running.**

## THE BENEFITS OF SYSTEMS SIMULATION

Simulation has become even more complex with electric cars. Engineers need to understand the physical behavior from molecules, cells and battery packs considering various parameters such as temperature, weather, aging or thermo-electrical losses. As the amount of energy is limited, it is even more important to analyze the usage of the vehicle. That implies simulating the impact of lighting, air-conditioning and infotainment, among other things. To meet all requirements, car makers need an environment which will allow them to optimize designs by simultaneously considering noise and vibrations, proper lubrication of the integrated gearbox, thermal management of the heat dissipated by high rotation speeds and electromagnetics losses, etc. **“All the items of the electric powertrain depend on each other so they can’t be developed individually. That is why systems simulation plays a key role in the conception of EVs. Experts need to ensure that all components are designed properly and work together as a system”**, stresses Thomas Reimer.

### Two parameters among others:



#### Noise & Vibration

EVs are known for being quieter than traditional cars, but the lack of sound from an engine means that other noises and vibrations (like tonal noises from electric machines and gearboxes) are much more apparent – and potentially unpleasant.

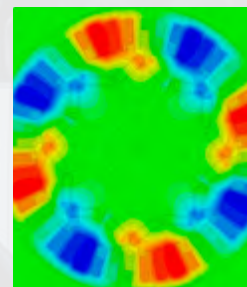

#### Electromagnetic performance

Cars have become computers on wheels. Electromagnetic simulation is crucial to ensure compatibility and compliance of all electric & electronic components tightly packed in any vehicle.

## NO TIME WASTED

A model-based approach eliminates tedious import and export operations as every piece of information is stored in one common database. For instance, computer-assisted design can be associated with the finite element method (FEM) representation of a model. When the design engineer needs to modify the geometry, let's say for packaging reasons, the structural engineer is notified automatically that the underlying geometry has been changed and that an update to the FEM representation needs to be performed. He can immediately re-run simulation cases to validate that the new geometry fulfils the load constraints.

## RETURN ON INVESTMENT

Car manufacturers need to master the holistic view on their product development. "OEMs must spend more time and effort in upfront engineering to reduce the later expensive and time-consuming iterations", sums up Thomas Reimer. The model-based systems engineering approach leads to a 30% decrease of development costs and a 20% reduction of time-to-market. Lastly, it ensures competitive performance through high quality and low warranty costs.



**-30%**  
development costs



**-20%**  
time-to-market



## WHY THE 3DEXPERIENCE PLATFORM MAKES A DIFFERENCE

### A SERVICE-CENTRIC OFFER

For an efficient e-drive development process with reduced time, design must receive feedback from all simulation domains. A cyber-physical twin of the real product is a great tool to simulate both the physical and functional aspects. “Traditional methods are not adapted to connected cars. OEMs which will integrate a model-based system engineering approach in their development will be the ones that will be able to stay on top of the game, moving from a product-centric to a service-centric offer”, explains Gauthier Fanmuy. That is exactly what the **3DEXPERIENCE** platform has to offer.

“We can basically simulate everything.”

— Helmut KASTLER,  
Project Director at Kreisel Electric.

### CLOSING GAPS

The digital platform changes the way simulation is used in organizations. On the one hand, it provides the advanced technologies that analyst communities use to validate detailed designs. On the other hand, it connects simulation to requirements, design and manufacturing data, thus establishing a “single source of truth” and closing the gaps between project participants. Automakers and suppliers can collaborate on one platform to design better electric drive systems.

**“We can integrate parameters like the heat transfer from the motor. We can set temperature limits. We can basically simulate everything”**, comments Helmut Kastler, Project Director at Kreisel Electric, a Dassault Systèmes client based in Austria. “With the **3DEXPERIENCE** platform, the role of simulation is shifting from purely validation to exploration, guidance and communication”, Thomas Reimer concludes.

**Simulation solutions on the 3DEXPERIENCE platform allow engineers to analyze:**



- Electromagnetic performance of the electric motor to optimize power density

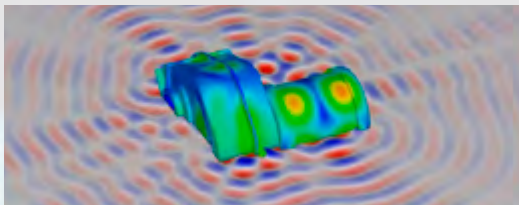

- Noise & vibration performance of the full system to offer a better acoustic experience and increase durability

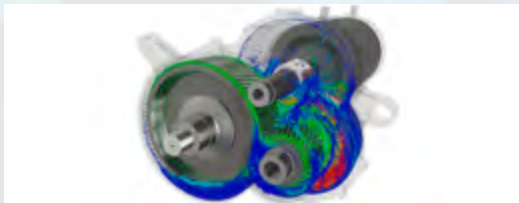

- Lubrication and cooling performance to improve operating efficiency

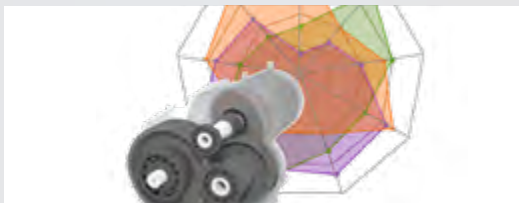

- System-level behavior to understand driving cycles performance and impact on other sub-systems



- Strength and stiffness performance to ensure the structural integrity of the system



## SUCCESS STORIES

Dassault Systèmes' customers already boast great achievements in the area of electric drive. A startup employing over 300 people in Los Angeles, Canoo, got a functional EV prototype on the road in just 19 months, doing all the geometry and 3D modeling with the CATIA applications. "As it is a cloud-based platform, we constantly know what each and every one is working on", shares Phil Weicker, Co-founder & Head of Powertrain & Electronics.



“We constantly know what each and every one is working on.”

— Phil WEICKER, Canoo Co-founder & Head of Powertrain & Electronics.

Simulation software and digital mock-ups allow Integral Powertrain to design for manufacturing and identify which suppliers will be used. "It avoids having to go through the learning curve with every motor, because all of that knowledge is captured in the rules-based design", appreciates technical director Luke Barker, Integral Powertrain



In France, Spark Racing Technology participates in the progress of Formula E racing by creating high performance electric cars and modules. It has used the **3DEXPERIENCE** platform to digitally design and simulate a completely new EV architecture in just two years.



Our **3DEXPERIENCE®** platform powers our brand applications, serving 11 industries, and provides a rich portfolio of industry solution experiences.

Dassault Systèmes, the **3DEXPERIENCE®** Company, provides business and people with virtual universes to imagine sustainable innovations. Its world-leading solutions transform the way products are designed, produced, and supported. Dassault Systèmes' collaborative solutions foster social innovation, expanding possibilities for the virtual world to improve the real world. The group brings value to over 250,000 customers of all sizes in all industries in more than 140 countries. For more information, visit [www.3ds.com](http://www.3ds.com).

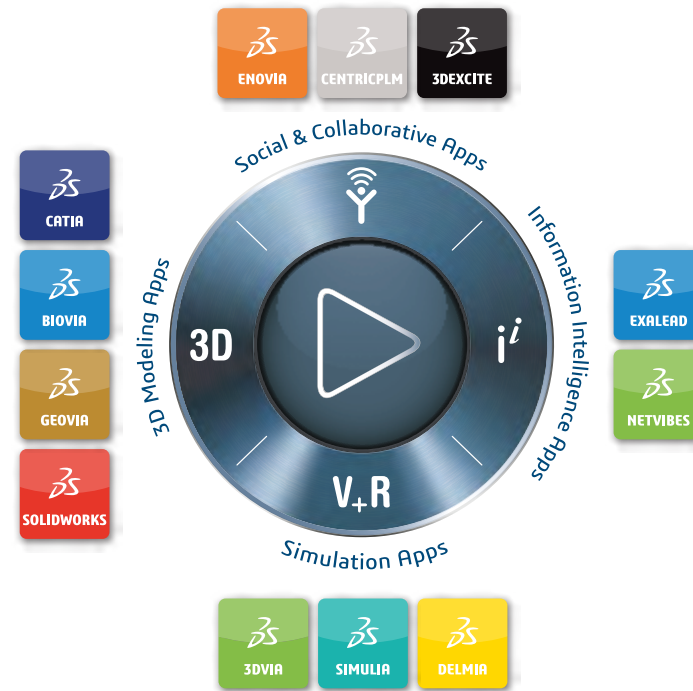

© 2020 Dassault Systèmes. All rights reserved. **3DEXPERIENCE**, the Compass icon, the 3DS logo, CATIA, BIOVIA, GEOVIA, SOLIDWORKS, ENOVIA, EXALEAD, NETVIBES, CENTRICPLM, 3DEXCITE, SIMULIA, DELMIA, and IP/VE are commercial trademarks or registered trademarks of Dassault Systèmes in France, the United States, and other countries. All other trademarks are owned by their respective owners. Use of any Dassault Systèmes or its subsidiaries trademarks is subject to their express written approval.